

**NOTES**

- I. **GENERAL**
  1. APPLICABLE CODE: CALIFORNIA BUILDING CODE, 2016 EDITION (CBC).
  2. DETAILS AND NOTES SHOWN IN THIS SET OF DRAWINGS AND TITLED "TYPICAL" ARE TYPICAL AND SHALL APPLY UNLESS OTHERWISE NOTED. DETAILS OF CONSTRUCTION NOT FULLY SHOWN SHALL BE OF THE SAME NATURE AS SHOWN IN TYPICAL DETAILS OR AS SHOWN FOR SIMILAR CONDITIONS.
  3. DO NOT SCALE STRUCTURAL DRAWINGS, USE WRITTEN DIMENSIONS. IF DIMENSIONS ARE OMITTED OR NOT CLEAR, CONTACT THE ARCHITECT.
  4. THE CONTRACTOR SHALL LOCATE AND PROTECT ALL EXISTING UTILITY LINES AND CONNECTIONS INCLUDING SEWER, WATER, GAS, AND ELECTRIC SERVICES BEFORE AND DURING HIS WORK.
  5. THE CONTRACTOR SHALL BE EXPECTED TO BE THOROUGHLY FAMILIAR WITH THE BUILDING SITE CONDITIONS, GRADES, DRAWINGS AND SPECIFICATIONS, MATERIAL DELIVERY FACILITIES AND ALL OTHER MATTERS AND CONDITIONS WHICH MAY AFFECT THE OPERATION AND COMPLETION OF WORK. THE CONTRACTOR SHALL ASSUME ALL RISKS CONCERNED WITH THE AFOREMENTIONED SITUATIONS, ACTIVITIES AND/OR OPERATIONS.
  6. DIMENSION LINES ON STRUCTURAL DRAWINGS ARE TO CENTER LINES OF ELEMENTS, UNLESS OTHERWISE NOTED.
  7. ADEQUATE TEMPORARY BRACING AND SHORING SHALL BE PROVIDED TO SUPPORT CONSTRUCTION MATERIALS, ERECTION EQUIPMENT AND ANY OTHER ERECTION LOADS IF REQUIRED.
  8. THE CONTRACTOR SHALL ASSUME SOLE AND COMPLETE RESPONSIBILITY FOR THE JOB SITE CONDITIONS DURING THE COURSE OF CONSTRUCTION OF THIS PROJECT, INCLUDING THE SAFETY OF ALL THE PERSONNEL AND PROPERTY. THIS REQUIREMENT SHALL APPLY CONTINUOUSLY AND SHALL NOT BE LIMITED TO NORMAL WORKING HOURS.
- II. **HAZARDOUS MATERIALS ON SITE**
  1. TUAN AND ROBINSON STRUCTURAL ENGINEERS ASSUMES NO RESPONSIBILITY FOR THE MANAGEMENT OF HAZARDOUS MATERIALS THAT MAY BE ON THE SITE. THE CONTRACTOR SHALL BE RESPONSIBLE FOR INSURING THAT PERSONNEL WITHIN THE WORK AREA ARE PROTECTED FROM EXPOSURE TO HAZARDOUS MATERIALS. IF MATERIALS ARE DISCOVERED THAT MAY BE HAZARDOUS, THE CONTRACTOR SHALL IMMEDIATELY NOTIFY THE OWNER AND CEASE WORK UNTIL CONDITIONS CAN BE MAINTAINED IN COMPLIANCE WITH ALL APPLICABLE REGULATIONS.
- III. **DESIGN CRITERIA - FOR NEW CONSTRUCTION ONLY**
  1. DEAD LOADS (DL) STRUCTURE 47 PSF
  2. LIVE LOADS (LL) PUBLIC WALKWAY 100 PSF
- IV. **WOOD FRAMING**
  1. ALL ROUGH FRAMING MEMBERS SHALL BE DOUGLAS FIR LUMBER MANUFACTURED AND GRADED IN ACCORDANCE WITH THE "STANDARD GRADING AND DRESSING RULES 16" OF THE WEST COAST LUMBERMAN'S ASSOCIATION. TIMBER MEMBERS TO CONFORM WITH THE FOLLOWING:
    - STUDS - #2 OR BETTER
    - JOISTS & RAFTERS - #2 OR BETTER
    - POSTS & BEAMS - #2 OR BETTER
    - SILLS - #2 PRESSURE TREATED
 ALL LUMBER IN DIRECT CONTACT WITH GROUND, CONCRETE OR MASONRY OR CLOSER TO EXPOSED GROUND THAN ALLOWED BY CODE SHALL BE TREATED LUMBER OR BE APPROVED WOOD OF NATURAL RESISTANCE TO DECAY AS LISTED IN THE CODE.
  2. TOUCH UP CUT ENDS OF PRESSURE PRESERVATIVE TREATED WOOD WITH PRESERVATIVE PAINT.
  3. ALL FASTENERS PENETRATING INTO PRESSURE PRESERVATIVE TREATED WOOD SHALL BE HOT-DIPPED GALVANIZED PER ASTM A153 OR STAINLESS STEEL. ALL FRAMING HARDWARE AND MISCELLANEOUS STEEL USED WITH PRESSURE PRESERVATIVE TREATED WOOD SHALL BE HOT-DIPPED GALVANIZED PER ASTM A653 OR STAINLESS STEEL. ALL FASTENERS FOR HOT-DIPPED GALVANIZED HARDWARE SHALL BE HOT-DIPPED GALVANIZED PER ASTM A153. ALL FASTENERS USED WITH STAINLESS STEEL HARDWARE SHALL BE STAINLESS STEEL.
  4. FRAMING: ARRANGE ALL HORIZONTAL MEMBERS WITH CROWN UP, UNLESS OTHERWISE NOTED.
  5. BLOCKING AND BRIDGING:
    - A. PROVIDE BRIDGING FOR FLOOR FRAMING WHERE REQUIRED BY 2016 CBC, CHAPTER 23, SECTION 2306/2015 NDS SECTION 4.4.1.2.
    - B. IN ALL STUD WALLS AND PARTITIONS, INCLUDING FURRED SPACES, PROVIDE 2" NOMINAL X WIDTH OF STUD, CONTINUOUS HORIZONTAL BLOCKING OR HERRINGBONE BRIDGING PLACED AT THE MID-HEIGHT OF STUDS OR SO THAT THE MAXIMUM DIMENSION OF ANY CONCEALED SPACE IS NOT OVER 10"-0".
    - C. ROOF RAFTERS SHALL BE BRIDGED EVERY 10 FEET BY SOLID 2 INCH NOMINAL THICK AND THE FULL DEPTH OF THE RAFTER, OR WOOD CROSS BRIDGING OF NOT LESS THAN 1 INCH BY 3 INCHES OR NAILED METAL CROSS BRIDGING OF EQUAL STRENGTH. WHEN CROSS BRIDGING IS USED, THE LOWER ENDS OF SUCH CROSS BRIDGING SHALL BE DRIVEN UP AND NAILED AFTER THE ROOF HAS BEEN NAILED.
  6. NAILING:
    - A. END DISTANCE, EDGE DISTANCE AND SPACING OF NAILS SHALL BE SUCH AS TO AVOID SPLITTING OF THE WOOD. WHERE 16d IS DRIVEN IN CLOSER THAN 3-1/2" O.C., PREDRILL HOLES TO AVOID SPLITTING OF THE WOOD.
    - B. THE PENETRATION OF NAILS INTO THE PIECE RECEIVING THE POINT SHALL BE NOT LESS THAN ONE-HALF OF THE LENGTH OF THE NAIL PROVIDED, HOWEVER, THAT 16d NAILS MAY BE USED TO CONNECT PIECES OF 2" NOMINAL THICKNESS.
    - C. ALL NAILS SHALL BE COMMON WIRE NAILS, UNLESS OTHERWISE INDICATED.
    - D. UNLESS SPECIFICALLY INDICATED OTHERWISE, MINIMUM NAILING FOR CONNECTING WOOD MEMBERS SHALL BE AS SET FORTH IN 2016 CBC, TABLE 2304.10.1.
    - E. NAILING NOT NOTED SHALL BE AT LEAST TWO NAILS AT ALL CONTACT POINTS USING 8d THRU 1" MATERIAL AND 16d THRU 2" MATERIAL.
  7. BOLTS: BOLT HOLE IN WOOD SHALL BE 1/32" TO 1/16" LARGER THAN BOLT, DEPENDING UPON THE BOLT SIZE, HOLES IN STEEL SHALL BE 1/16" OVERSIZE. PROVIDE CUT WASHERS UNDER HEAD AND NUT UNLESS SQUARE PLATE OR MALLEABLE IRON WASHERS ARE NOTED ON DRAWINGS. LENGTH OF THREAD SHALL BE SUCH THAT THREADS DO NOT BEAR AGAINST WOOD OR STEEL. PROVIDE WASHERS AS REQUIRED TO ALLOW NUTS TO BE TAKEN UP TIGHT. ALL NUTS SHALL BE TIGHTENED WHEN PLACED AND RE-TIGHTENED AT COMPLETION OF JOB OR IMMEDIATELY BEFORE CLOSING WITH FINAL CONSTRUCTION. BOLTS SHALL BE UNFINISHED AND OF SIZES SHOWN. LENGTHS SHALL BE CAREFULLY CHECKED SO THAT THE PROJECTION IS NOT LESS THAN 1/16" NOR MORE THAN 1/2" PAST END OF NUT.
  8. TIMBER FASTENERS INDICATED ON DRAWINGS SHALL BE AS IDENTIFIED BY PROPRIETARY NAMES, OR EQUAL, AND SHALL BE FASTENED IN ACCORDANCE WITH MANUFACTURER'S SPECIFICATIONS. FASTENERS DESIGNATED ON DRAWINGS ARE "STRONG-TIE" CONNECTORS AS MANUFACTURED BY THE SIMPSON COMPANY, SAN LEANDRO, CA, UNLESS OTHERWISE NOTED ON PLANS AND/OR DETAILS.

- ABBREVIATIONS**
- (A) ABOVE
  - ASTM AMERICAN SOCIETY FOR TESTING AND MATERIALS
  - ATR ALL THREADED ROD
  - AWS AMERICAN WELDING SOCIETY
  - (B) BELOW
  - BLKG BLOCKING
  - BM BEAM
  - B.O. BOTTOM OF
  - BOT BOTTOM
  - BTWN BETWEEN
  - CBC CALIFORNIA BUILDING CODE
  - CCR CALIFORNIA CODE OF REGULATIONS
  - CL CENTERLINE
  - CLR CLEAR
  - CONN CONNECTION
  - CONT CONTINUOUS
  - CP COMPLETE PENETRATION WELD
  - DBL DOUBLE
  - DET DETAIL
  - DIA DIAMETER
  - DM DIMENSION
  - DWG DRAWING
  - DWGS DRAWINGS
  - (E) EXISTING
  - EA EACH
  - EL ELEVATION
  - EN EDGE NAILING
  - EQ EQUAL
  - ES EACH SIDE
  - EW EACH WAY
  - EXT EXTERIOR
  - FN FIELD NAILING
  - FO FACE OF
  - FOS FACE OF STUD
  - FT FEET
  - GA GAUGE
  - GALV GALVANIZED
  - GB GRADE BEAM
  - HGR HANGER
  - HORIZ HORIZONTAL
  - I MOMENT OF INERTIA
  - IBC INTERNATIONAL BUILDING CODE
  - KCC INTERNATIONAL CODE COUNCIL
  - ICC INTERNATIONAL CODE COUNCIL (EVALUATION SERVICE)
  - ID INSIDE DIAMETER
  - IF INSIDE FACE
  - INT INTERIOR
  - JT JOINT
  - JST JOIST
  - KD KILN DRIED
  - LB POUND
  - LG LONG
  - LLH LONG LEG HORIZONTAL
  - LLV LONG LEG VERTICAL
  - LSH LONG SLOTTED HOLE
  - MAX MAXIMUM
  - MB MACHINE BOLT
  - MTL METAL
  - MFR MANUFACTURING MANUFACTURER
  - MIN MINIMUM
  - MISC MISCELLANEOUS
  - (N) NEW
  - NC NOT IN CONTRACT
  - N.O. NUMBER
  - NOM NOMINAL
  - NTS NOT TO SCALE
  - O/O OVER
  - OC OR
  - O.C. ON CENTER
  - OD OUTSIDE DIAMETER
  - OF OUTSIDE FACE
  - OH OPPOSITE HAND
  - OPNG OPENING
  - OPP OPPOSITE
  - PL PLATE
  - PLF POUNDS PER LINEAR FOOT
  - PP PARTIAL PENETRATION WELD
  - PT PRESERVATIVE TREATED
  - RAD RADIUS
  - REQ REQUIRED
  - REQD REQUIRED
  - S SECTION
  - (S) SLOPING
  - SIM SIMILAR
  - SEC SECTION
  - SHT SHEET
  - SHTG SHEATHING
  - SPCG SQUARE
  - SSH SHORT SLOTTED HOLE
  - STD STANDARD
  - STL STEEL
  - SYM SYMMETRICAL
  - T&B TOP AND BOTTOM
  - T&G TONGUE AND GROOVE
  - THK THICK
  - THRD THREADED
  - T.O. TOP OF
  - TYP TYPICAL
  - UNLESS OTHERWISE NOTED
  - UON UNLESS OTHERWISE NOTED
  - VERT VERTICAL
  - VIF VERIFY IN FIELD
  - W/ WITH
  - WD WOOD
  - WP WORK POINT

DESCRIPTION OF BUILDING ELEMENTS	NUMBER AND TYPE OF FASTENER	SPACING AND LOCATION
<b>ROOF</b>		
1. BLOCKING BETWEEN CEILING JOISTS, RAFTERS OR TRUSSES TO TOP PLATE OR OTHER FRAMING BELOW	3-8d COMMON; OR 3-10d BOX; OR 3-3"x0.131" NAILS	EACH END, TOENAIL
BLOCKING BETWEEN RAFTERS OR TRUSS NOT AT THE WALL TOP PLATE, TO RAFTER OR TRUSS	2-8d COMMON; OR 2-16d COMMON; OR 3-3"x0.131" NAILS	EACH END, TOENAIL END NAIL
FLAT BLOCKING TO TRUSS AND WEB FILLER	16d COMMON; OR 3"x0.131" NAILS	6" o.c. FACE NAIL
2. CEILING JOISTS TO TOP PLATE	3-8d COMMON; OR 3-10d BOX; OR 3"x0.131" NAILS	EACH JOIST, TOENAIL
3. CEILING JOISTS NOT ATTACHED TO PARALLEL RAFTER, LAPS OVER PARTITION (NO THRUST)	3-16d COMMON; OR 4-10d BOX; OR 4-3"x0.131" NAILS	FACE NAIL
4. CEILING JOIST TO PARALLEL RAFTER (HEEL JOINT)	SEE DETAILS	SEE DETAILS
5. COLLAR TIE TO RAFTER	3-10d COMMON; OR 4-10d BOX; OR 4-3"x0.131" NAILS	FACE NAIL
6. RAFTER OR ROOF TRUSS TO TOP PLATE	3-10d COMMON; OR 3-16d BOX; OR 4-10d BOX; OR 4-3"x0.131" NAILS	TOENAIL
7. ROOF RAFTERS TO RIDGE VALLEY OR HIP RAFTERS; OR ROOF RAFTER TO 2-INCH RIDGE BEAM	2-16d COMMON; OR 3-10d BOX; OR 3-3"x0.131" NAILS	END NAIL
	3-10d COMMON; OR 3-16d BOX; OR 4-10d BOX; OR 4-3"x0.131" NAILS	TOENAIL
<b>WALL</b>		
8. STUD TO STUD (NOT AT SHEAR WALLS/BRACED WALL PANELS)	16d COMMON; OR 16d BOX; OR 3"x0.131" NAIL	24" o.c. FACE NAIL 16" o.c. FACE NAIL
9. STUD TO STUD AND ABUTTING STUDS AT INTERSECTING WALL CORNERS (AT SHEAR WALLS/BRACED WALL PANELS)	16d COMMON; OR 16d BOX; OR 3"x0.131" NAIL	16" o.c. FACE NAIL 12" o.c. FACE NAIL
10. BUILT-UP HEADER (2" TO 2" HEADER)	16d COMMON; OR 16d BOX	16" o.c. EACH EDGE FACE NAIL 12" o.c. EACH EDGE FACE NAIL
11. CONTINUOUS HEADER TO STUD	4-8d COMMON; OR 4-10d BOX	TOENAIL
12. TOP PLATE TO TOP PLATE	16d COMMON; OR 16d BOX; OR 3"x0.131" NAIL	16" o.c. FACE NAIL 12" o.c. FACE NAIL
13. TOP PLATE TO TOP PLATE, AT END JOINTS	8-16d COMMON; OR 12-10d BOX; OR 12-3"x0.131" NAIL	EACH SIDE OF END JOINT, FACE NAIL (MINIMUM 24" LAP SPlice LENGTH EACH SIDE OF END JOINT)
14. BOTTOM PLATE TO JOIST, RIM JOIST, BAND JOIST OR BLOCKING (NOT AT SHEAR WALLS/BRACED WALL PANELS)	16d COMMON; OR 16d BOX; OR 3"x0.131" NAIL	16" o.c. FACE NAIL 12" o.c. FACE NAIL
15. BOTTOM PLATE TO JOIST, BAND JOIST, BAND JOIST OR BLOCKING AT SHEAR WALLS/BRACED WALL PANELS	2-16d COMMON; OR 3-16d BOX; OR 4-3"x0.131" NAILS	16" o.c. FACE NAIL
16. STUD TO TOP OR BOTTOM PLATE	4-8d COMMON; OR 4-10d BOX; OR 4-3"x0.131" NAILS	TOE NAIL
17. TOP OR BOTTOM PLATE TO STUD	2-16d COMMON; OR 3-10d BOX; OR 3-3"x0.131" NAILS	END NAIL FACE NAIL
18. TOP PLATES, LAPS AT CORNERS AND INTERSECTIONS	2-16d COMMON; OR 3-10d BOX; OR 3-3"x0.131" NAILS	FACE NAIL
19. 1" BRACE TO EACH STUD AND PLATE	2-8d COMMON; OR 2-10d BOX; OR 2-3"x0.131" NAILS	FACE NAIL
20. 1"x6" SHEATHING TO EACH BEARING	2-8d COMMON; OR 2-10d BOX	OR FACE NAIL
21. 1"x8" AND WIDER SHEATHING TO EACH BEARING	3-8d COMMON; OR 3-10d BOX	OR FACE NAIL
<b>FLOOR</b>		
22. JOIST TO SILL, TOP PLATE, OR GIRDER	3-8d COMMON; OR 3-10d BOX; OR 3-3"x0.131" NAILS	TOENAIL
23. RIM JOIST, BAND JOIST, OR BLOCKING TO TOP PLATE, SILL OR OTHER FRAMING BELOW	8d COMMON; OR 10d BOX; OR 3"x0.131" NAILS	6" o.c., TOENAIL
24. 1"x6" SUBFLOOR OR LESS TO EACH JOIST	2-8d COMMON; OR 2-10d BOX	FACE NAIL
25. 2" SUBFLOOR TO JOIST OR GIRDER	2-16d COMMON	FACE NAIL
26. 2" PLANK (PLANK & BEAM - FLOOR & ROOF)	2-16d COMMON	EACH BEARING, FACE NAIL
27. BUILT-UP GIRDERS AND BEAMS, 2" LUMBER LAYERS	20d COMMON; OR 10d BOX; OR 3"x0.131" NAILS	32" o.c., FACE NAIL AT TOP & BOT STAGGERED ON OPP SIDES 24" o.c., FACE NAIL AT TOP & BOT STAGGERED ON OPP SIDES
28. LEDGER STRIP SUPPORTING JOISTS OR RAFTERS	3-16d COMMON; OR 4-10d BOX; OR 4-0.131" NAILS	ENDS AND AT EACH SPLICE, FACE NAIL EACH JOIST OR RAFTER, FACE NAIL
29. JOIST TO BAND JOIST OR RIM JOIST	3-16d COMMON; OR 4-10d BOX; OR 4-0.131" NAILS	END NAIL
30. BRIDGING OR BLOCKING TO JOIST, RAFTER OR TRUSS	2-8d COMMON; OR 2-10d BOX; OR 2-3"x0.131" NAILS	EACH END, TOENAIL

DESCRIPTION OF BUILDING ELEMENTS	NUMBER AND TYPE OF FASTENER	SPACING AND LOCATION
<b>WOOD STRUCTURAL PANELS (WSP), SUBFLOOR, ROOF AND INTERIOR WALL SHEATHING TO FRAMING AND PARTICLEBOARD WALL SHEATHING TO FRAMING<sup>1</sup></b>		
PANEL THICKNESS	EDGES (INCHES)	INTERMEDIATE SUPPORTS (INCHES)
31. 3/8" - 1/2"	6d COMMON OR DEFORMED (SUBFLOOR AND WALL) 8d BOX OR DEFORMED (ROOF) 2"x0.113" NAIL (SUBFLOOR AND WALL) 2"x0.113" NAIL (ROOF)	6 6 4 8
32. 19/32" - 3/4"	8d COMMON; OR 6d DEFORMED 2"x0.113" NAIL	6 4 8
33. 7/8" - 1 1/4"	10d COMMON; OR 8d DEFORMED	6 12
<b>OTHER EXTERIOR WALL SHEATHING</b>		
34. 1/2" FIBERBOARD SHEATHING <sup>2</sup>	1 1/2" GALVANIZED ROOFING NAIL	3 6
35. 25/32" FIBERBOARD SHEATHING <sup>2</sup>	1 3/4" GALVANIZED ROOFING NAIL	3 6
<b>WOOD STRUCTURAL PANELS, COMBINATION SUBFLOOR UNDERLAYMENT TO FRAMING</b>		
36. 3/4" OR LESS	8d COMMON; OR 6d DEFORMED	6 12
37. 7/8" - 1"	8d COMMON; OR 8d DEFORMED	6 12
38. 1 1/8" - 1 1/4"	10d COMMON; OR 8d DEFORMED	6 12
<b>PANEL SIDING TO FRAMING</b>		
39. 1/2" OR LESS	6d CORROSION-RESISTANT SIDING; OR 6d CORROSION RESISTANT CASING	6 12
40. 5/8"	8d CORROSION-RESISTANT SIDING; OR 6d CORROSION RESISTANT CASING	6 12
<b>INTERIOR PANELING</b>		
41. 1/4"	4d CASING; OR 4d FINISH	6 12
42. 3/8"	6d CASING; OR 6d FINISH (PANEL SUPPORTS AT 24")	6 12

**NOTE:**

1. NAILS SPACED AT 6" o.c. AT INTERMEDIATE SUPPORTS WHERE SPANS ARE 48" OR MORE. FOR NAILING OF WOOD STRUCTURAL PANEL AND PARTICLEBOARD DIAPHRAGMS AND SHEAR WALLS, SEE PLANS AND DETAILS THIS SET. NAILS FOR WALL SHEATHING ARE PERMITTED TO BE COMMON, BOX OR CASING.
2. SPACING SHALL BE 6" o.c. ON THE EDGE AND 12" o.c. AT INTERMEDIATE SUPPORTS FOR NON-STRUCTURAL APPLICATIONS. PANEL SUPPORTS AT 16" o.c. (20" o.c. IF STRENGTH AXIS IN THE LONG DIRECTION OF THE PANEL, UNLESS OTHERWISE NOTED).
3. WHERE A RAFTER IS FASTENED TO AN ADJACENT PARALLEL CEILING JOIST IN ACCORDANCE WITH THIS SCHEDULE AND THE CEILING JOIST IS FASTENED TO THE TOP PLATE IN ACCORDANCE WITH THIS SCHEDULE, THE NUMBER OF TOENAILS IN THE RAFTER SHALL BE PERMITTED TO BE REDUCED BY ONE NAIL.
4. TABLE SHOWS MINIMUM NAILING UNLESS OTHERWISE NOTED IN PLANS OR DETAILS.

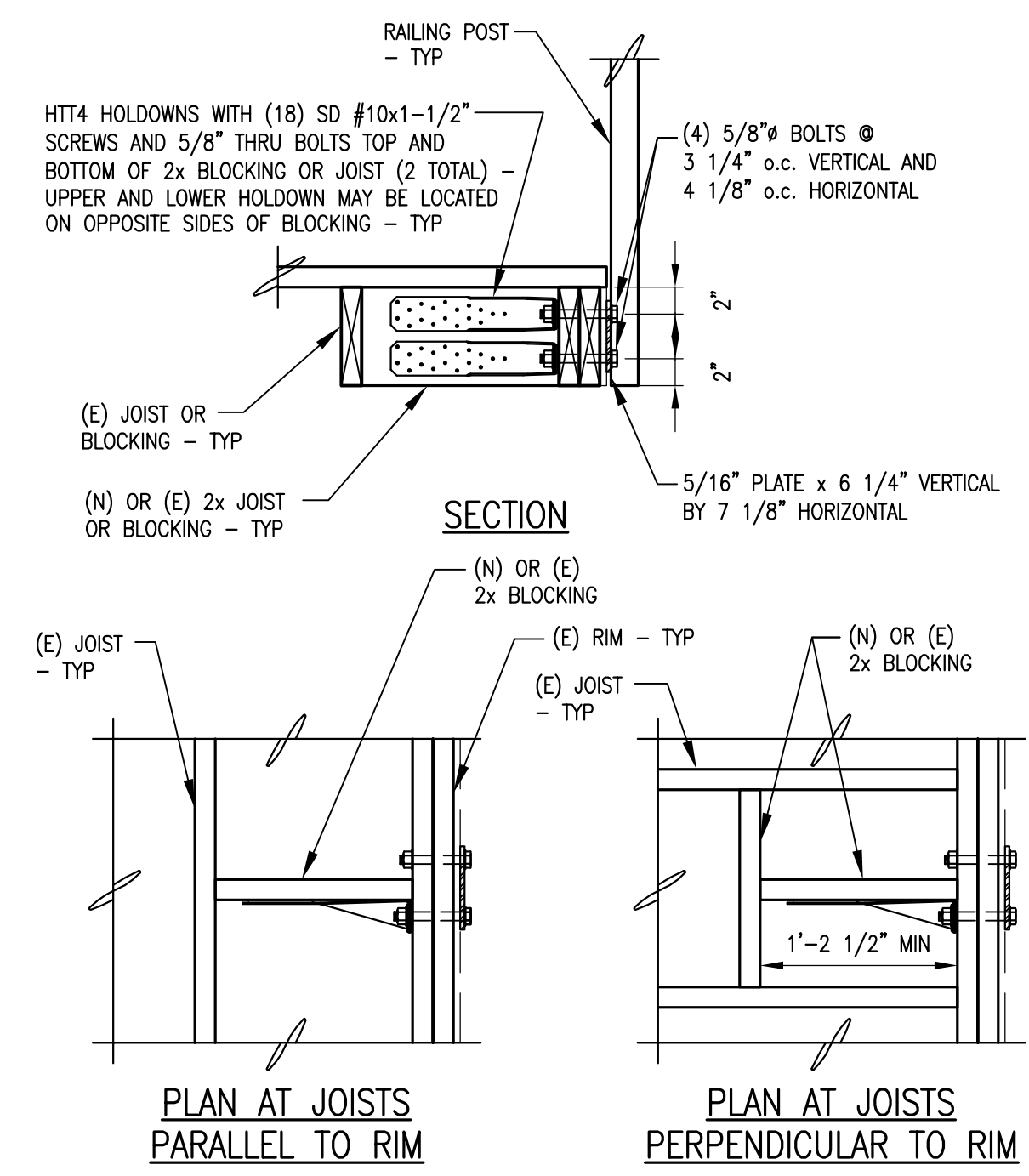

**BASIS** Architecture & Consulting

2130 FOURTH ST  
SAN RAFAEL, CA 94901  
PHONE (415) 457-6035

P.O. BOX 150539  
SAN RAFAEL, CA 94915

CHARLES PICK, ARCHITECT

**TR**

Tuan and Robinson  
Structural Engineers, Inc.  
444 Gene Sisk, Suite 111  
San Francisco, CA 94105  
Tel 415 937 2400 Fax 415 937 2483  
TSE Project Number: 2018.075.00

This document, the ideas and design incorporated therein, are the intellectual property of Tuan and Robinson Structural Engineers, Inc. and is not to be used, in whole or in part, for any other project without written authorization. ©COPYRIGHT 2018

STAMP

REGISTERED PROFESSIONAL ENGINEER  
ALAN E. ROBINSON  
No. S3971  
Expires 12-31-2019  
STRUCTURAL  
STATE OF CALIFORNIA

DRAWING REVISION LOG

PERMIT SUBMITTAL	DATE
	06-08-2018

PROJECT NAME:  
**DESERT HAVEN (QUEENS MOTEL) RE-DEVELOPMENT**

PROJECT LOCATION:  
16959 STODDARD WELLS RD  
VICTORVILLE, CA 92395

SHEET TITLE:  
**GENERAL NOTES, ABBREVIATIONS AND TYPICAL DETAILS**

SCALE: NONE

**S1.0**

PLOT DATE: 06-08-2018 - 5:29pm  
FILE NAME: U:\Projects\2018\075\00\Draws\2018.075.00\_S1.0.dwg